

Distributed Electric Propulsion (DEP) Testing

With the Flight Stand **15**



*Metal structure not included

Introduction

Our distributed electric propulsion (DEP) testing platform allows you to test up to 8 motors and propellers simultaneously. The component Flight Stand 15 thrust stands and software allow you to characterize ≤ 8 powertrains' thrust, torque, RPM, power, efficiency and more.

Versions Available

- **FS15 Standard:** essential performance characteristics for static tests over our standard range of values. Constant error rate across measured values.
- **FS15 Pro:** enhanced performance for dynamic tests over a wider range of values with very high accuracy. A higher sampling rate and low error based on measured value.

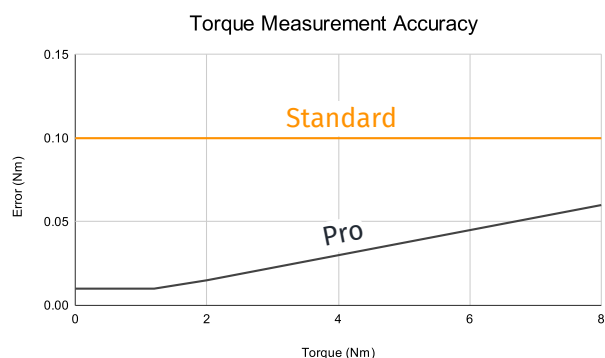
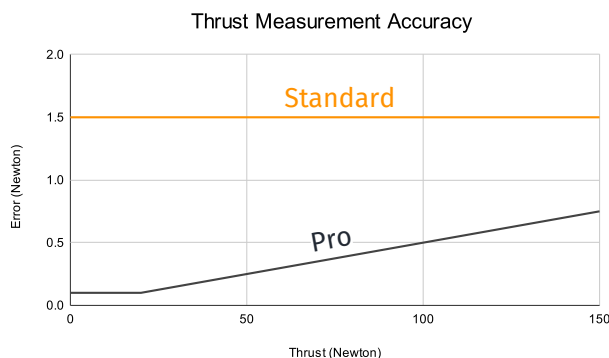

Possible Layouts

How you organize your DEP testing system is up to you. The Flight Stands can be bolted directly to the ground, to a railing system, or to a structure representing the layout of your drone.



How it Works

Step 1: Place and secure your Flight Stands (up to 8).



Step 2: Connect the EMUs to the powertrains. **1 EMU per powertrain.** Pass the red power wire through the Hall sensor and connect both wires to the voltage sensor on the back.

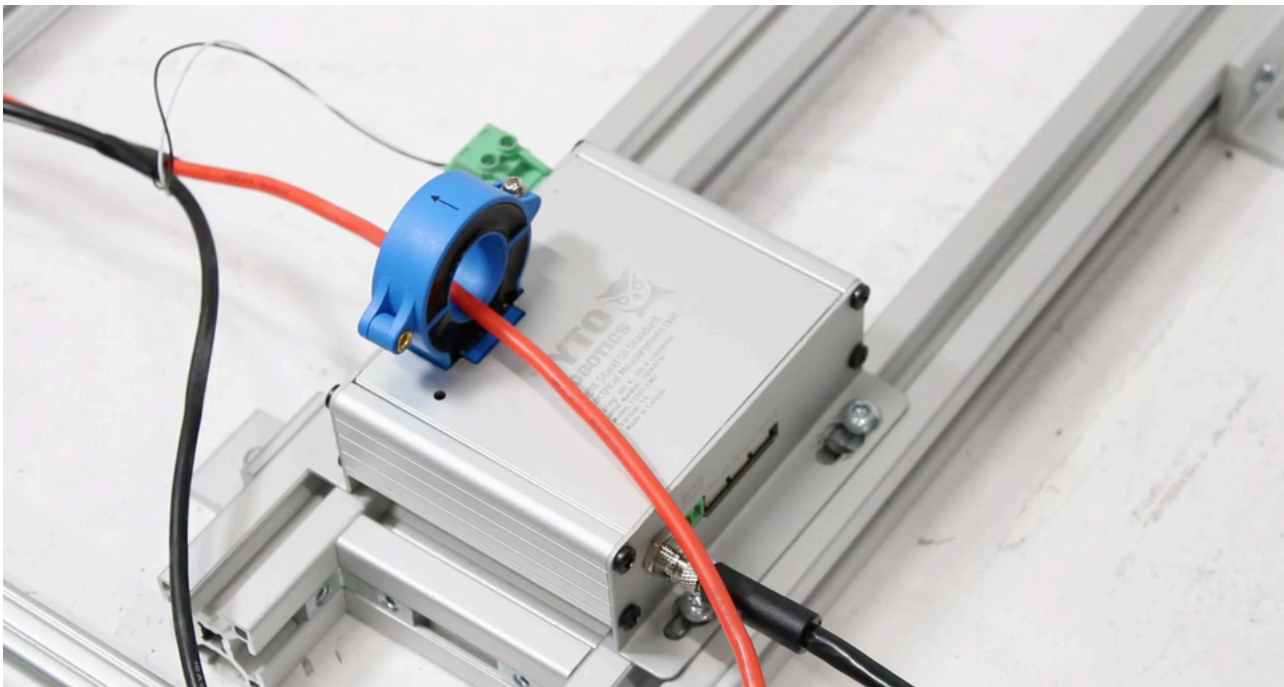

How it Works continued

Step 3: Connect the Sync Hub to the Flight Stand and your EMU (front), then a power outlet and your computer (back). There is **1 Sync Hub** for every **2 powertrains**.

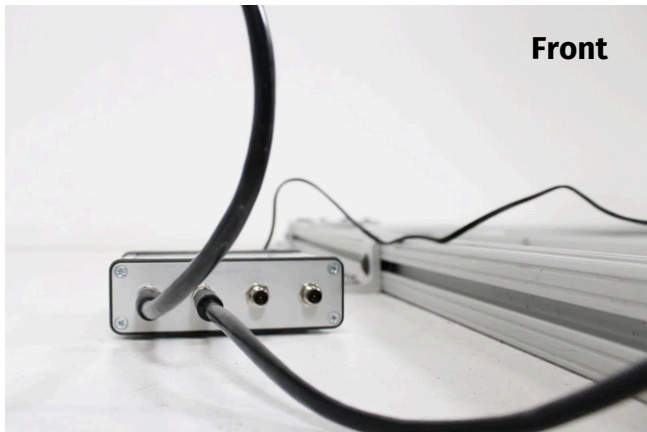

Step 4: Open the Flight Stand software on your computer and map your powertrains (name them by type or position so you can keep track of them later).

Step 5: Activate your ESC then run your test in one of four ways:

1. Run a manual test using the throttle sliders
2. Create an automated test by entering throttle values and timings in the table provided.
3. Upload a .CSV file of throttle values and timings, which will file in the table automatically.
4. Use Python to program your test using the Python API.

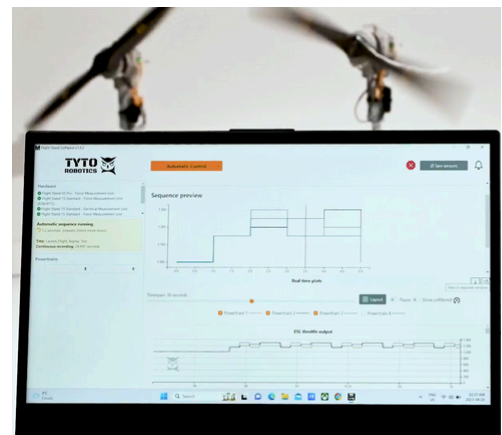
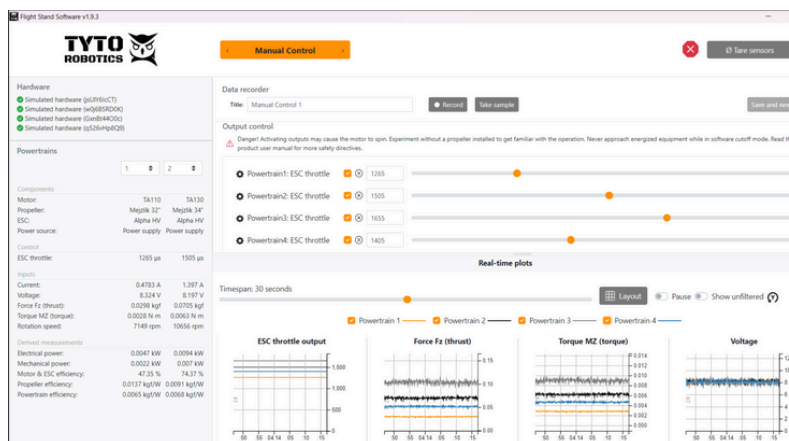

Step 6: After your test, adjust your noise and sampling settings, then export your data to .CSV.

For a video demonstration of how it works, [click here](#).

Technical Specifications

	Specification	Standard	Pro
Basic Information	Storage temp & humidity	23°C, 20% to 80% suggested	23°C, 20% to 80% suggested
	Operating temp & humidity	0°C to 40°C, 20% to 80% suggested	0°C to 40°C, 20% to 80% suggested
	Dimensions	28" x 12" x 6"	28" x 12" x 6"
	Input power / Output power	90 - 264 VAC, 1 A input adapts into 9 V, 2 A	90 - 264 VAC, 1 A input adapts into 9 V, 2 A
Measurement Information	Sampling rate	100 Hz	1,000 Hz
	Thrust calibration	Internal standard (26 points, push & pull)	ASTM E74 standard (211 points, push & pull)
	Torque calibration	Internal standard (30 points, CW & CCW)	ASTM E2624 (213 points, CW & CCW)
	Crosstalk calibration	Yes with 48 points	Yes with 1056 points
	Angular speed	400 to 30 000 RPM	400 to 30 000 RPM
Voltage and Current	Voltage range	0 V to 180 V	0 V to 180 V
	Voltage resolution	0.001 V	0.001 V
	Voltage accuracy	1% measured value from 5 V to 180 V	1% measured value from 5 V to 180 V
	Current range	0 to 150 A	0 to 150 A
	Current resolution	0.001 A	0.001 A
	Current accuracy	1% from 5 A to 150 A	1% from 5 A to 150 A
Thrust	Range	±150 N	±150 N
	Resolution	0.05 N	0.002 N
	Accuracy	± 1.5 N	±0.5% of measured value, with lower limit of ±20 N (± 0.1 to ± 0.75 N)
	Temperature effect	±0.4 N per 10 degree Celsius	±0.4 N per 10 degree Celsius
Torque	Range	±8 Nm	±8 Nm
	Resolution	0.005 Nm	0.001 Nm
	Accuracy	± 0.1 Nm	±0.75% of measured value, with lower limit of 1.2 Nm (± 0.01 to ± 0.06 Nm)
	Temperature effect	±0.15 Nm per 10 degree Celsius	±0.15 Nm per 10 degree Celsius
RPM Sensor	Range	0 to 30 000 RPM	0 to 30 000 RPM
	Operating environment	Indoor	Indoor
	Accuracy	±1 RPM	±1 RPM
Temperature	PT100	-30 °C to 100 °C, ±2 °C	-30 °C to 100 °C, ±2 °C
General analog inputs	Range	N/A	2 inputs of ±10 V differential.
	Resolution	N/A	0.001 V
	Accuracy	N/A	±0.5% of measured value ±0.25 V
	Supply pin	N/A	5 V ± 0.1 V 30 mA max
External Inputs and Outputs	Connect CAN ESCs, pressure sensors, sound level sensors, and more	Included	Included

Key Features

Here's why the Flight Stand is the best propulsion testing tool on the market:

- **Frictionless measurement:** our tools have a solid-state system for measuring thrust and torque, meaning there are no moving parts between the motor and load cells. This design significantly improves the accuracy of measurements and eliminates the need for bearings and hinges, which cause friction and are prone to misalignment.
- **ASTM Calibration:** our Pro thrust stands are rigorously calibrated to ASTM standards to ensure maximum measurement accuracy. Thrust is calibrated with the 211-point ASTM E74 procedure and torque is calibrated with the 213-point ASTM E2624 procedure.
- **Ultra compact design:** the compact shape of the Flight Stand ensures that there is minimal airflow disturbance from the tool's hardware and wiring. This promotes more realistic measurements and testing conditions that more closely mimic flight.
- **Realistic dual motor testing:** it is possible to perform dual motor tests in 3+ configurations with the Flight Stand, each representing a different aircraft design. In the back-to-back testing configuration, the motors are separated by a distance as little as 91 mm, similar to the distance you'd have in a multicopter.
- **Superior software experience:** our software allows you to perform manual or automated tests with no programming required. We also offer a Python API, data management system with plots, tables, filtering and resampling capability, and the ability to connect CAN ESCs and external sensors.
- **Exceptional customer support:** our team is ready to respond to any questions you may have in a friendly and timely manner.

Award Winning

In 2022, the Flight Stand won the Regional Innovation Award from the Order of Engineers of Quebec, thanks to its ground-breaking design and capabilities.



Hardware and Electronics

The Flight Stand 15 DEP testing platform comes fully equipped with software, hardware and electronics, including:

- Force Measurement Units: measure thrust and torque
- Electric Measurement Units: measure current and voltage
- Tubular structures: support the FMU and propulsion system, protects wiring
- Sync Hubs: connect the thrust stand to the software
- Temperature probes: record the temperature at the desired location
- Optical RPM probes: provide a precise measurement of the motor's rotation speed
- Flight Stand Software



Tubular Structure

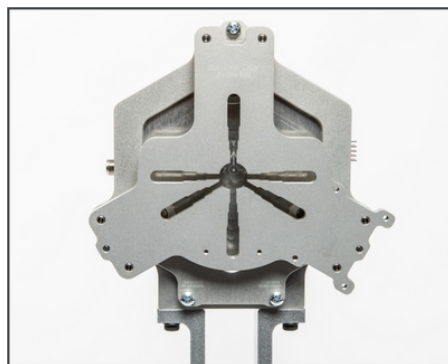

Force Measurement Unit



Sync Hub



Electrical Measurement Unit

The Force Measurement Unit can be used with the tubular structure or independently in a testing setup that better meets your needs.

Software

The Flight Stand Software controls your thrust stand and records data. You can manually control tests with a throttle slider or automate tests using a table, data from a .CSV file, or the Python API. Supported protocols include:

ESC:

Standard PWM: 50, 100, 200, 300, 400, 490 Hz

Dshot: 150, 300, 600

Oneshot: 42, 125

Multishot

*CAN

Servos:

Standard PWM: 50, 100, 200,

300, 400, 490 Hz

With the Flight Stand Software you can:

- Control the thrust stand manually and view live data as it is recorded
- Automate tests with an easy-to-use interface that requires no programming
- Control the whole system from a Python API
- Connect external analog sensors with the Input Transformations tab
- Upload .CSV files from your flight controller to perform flight replay tests
- Save tests directly in the software and/or export them as .CSV files
- Re-sample data for smaller files and adjust sensor noise filtering
- Map and test up to 8 powertrains simultaneously (DEP testing)

*Our I/O API also allows you to connect CAN ESCs.

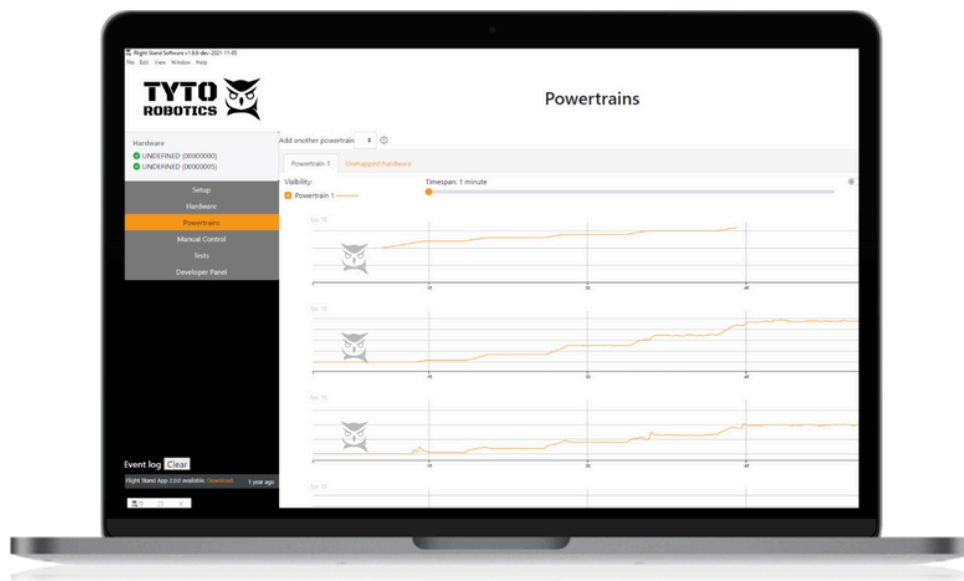

Technical Drawings

Force Measurement Unit:

Can be attached to the tubular structure provided or fixed to your own structure

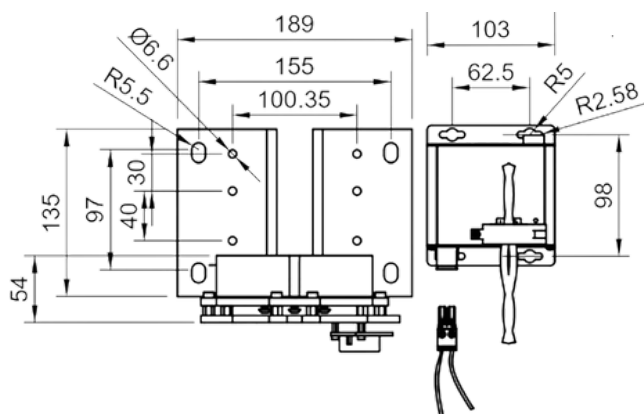
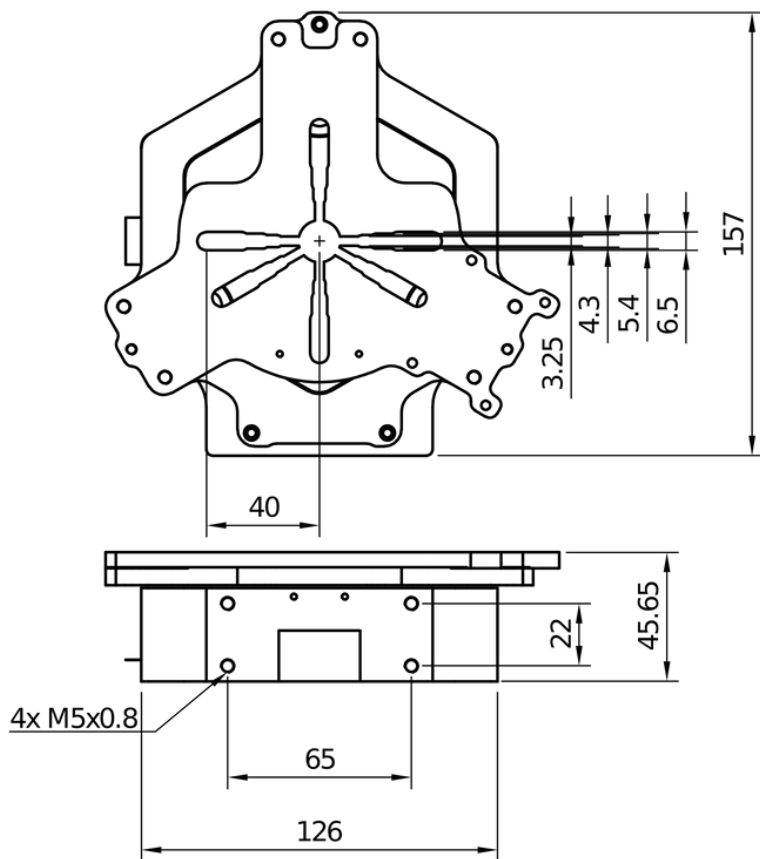

Stand Components:

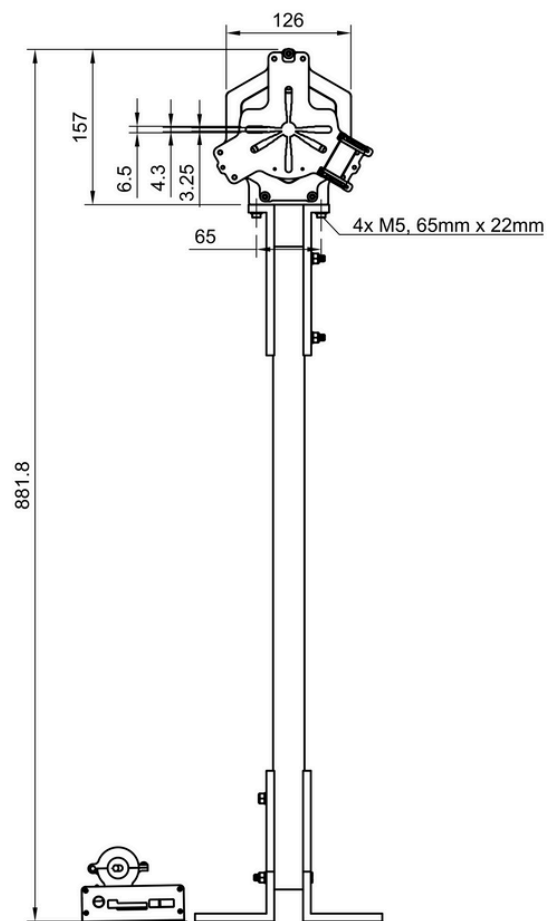

Electrical Measurement Unit

